

LOC		DIST		REVISIONS			
P	LTR	DESCRIPTION	DATE	DMN	APVD		
G		REVISED PER ECR-15-010337	23JUL2015	RK	SC		

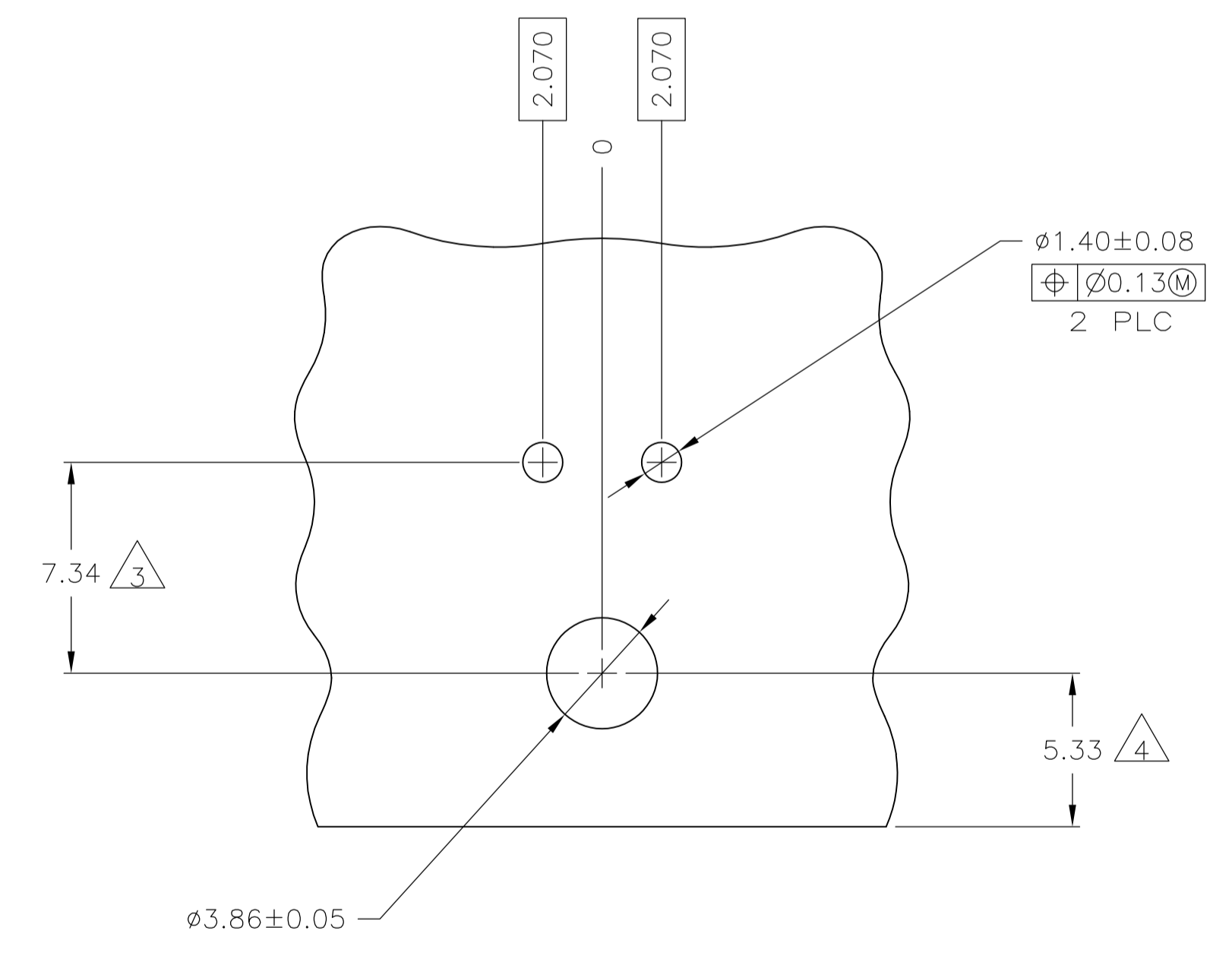
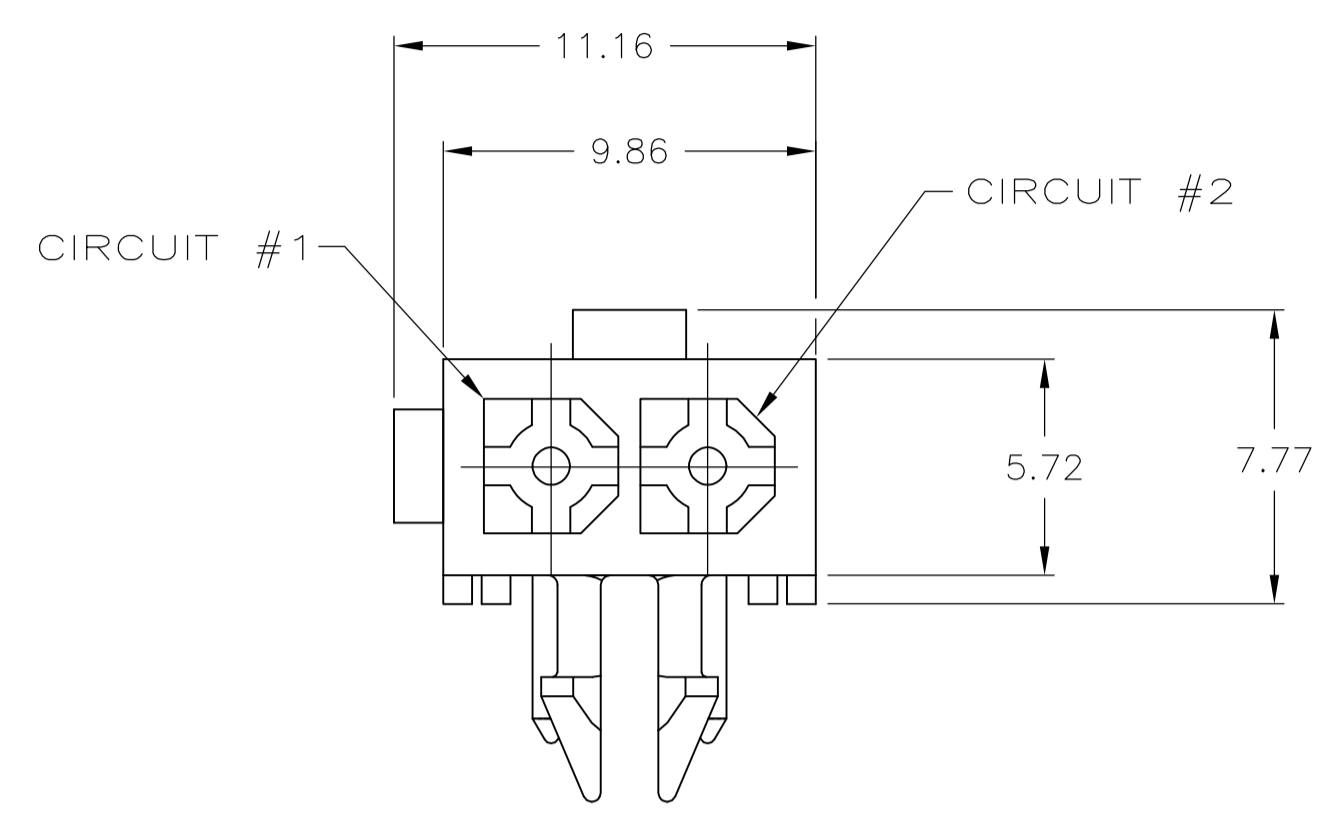
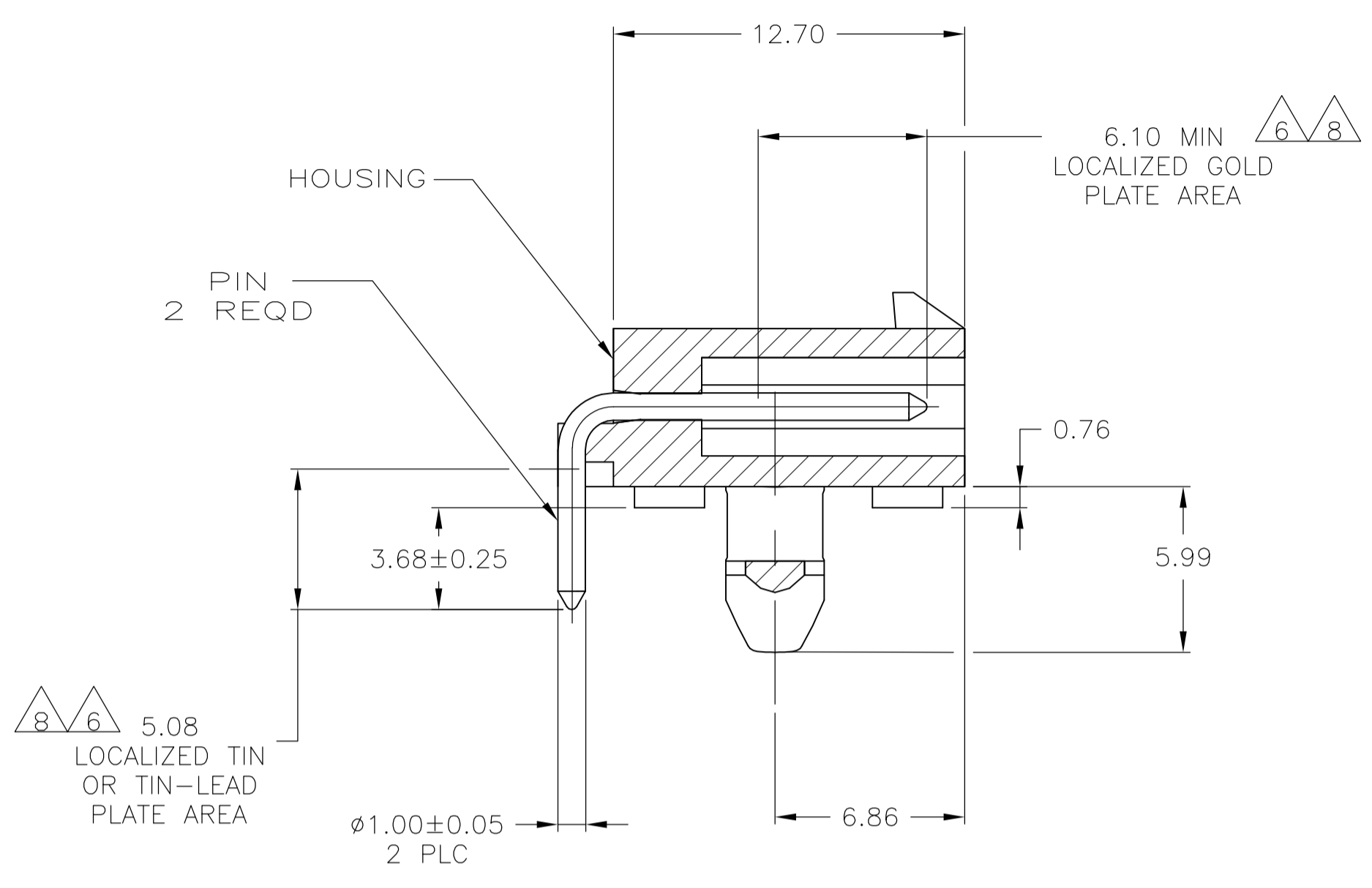

RECOMMENDED MOUNTING HOLE PATTERN FOR 1.57 THICK P.C. BOARD

- PINS TO COMPLY WITH AMP SOLDERABILITY SPEC 109-11-3.
- MATES WITH PLUG P/N 172165-1.
- COORDINATE DIMENSION APPLIES FROM CENTER OF ACTUAL FEATURE.
- RECOMMENDED FOR EDGE MOUNTING.
- 0.00381 MIN MATTE TIN LEAD OVER 0.00127 MIN NICKEL ENTIRE LENGTH OF PIN.
- 0.00076 MIN GOLD PLATE IN THE LOCALIZED PLATE AREA, 0.00381 MIN MATTE TIN LEAD IN THE LOCALIZED PLATE AREA, BOTH OVER 0.00127 MIN NICKEL.
- 0.00381 MIN MATTE TIN OVER 0.00127 MIN NICKEL ENTIRE LENGTH OF PIN.
- 0.00076 MIN GOLD PLATE IN THE LOCALIZED GOLD PLATE AREA, 0.00381 MIN MATTE TIN IN THE LOCALIZED TIN PLATE AREA, BOTH OVER 0.00127 MIN NICKEL.

MM	IN	MM	IN
2.070	.0815	-	-
1.57	.062	12.70	.500
1.40	.055	9.86	.388
1.00	.039	7.34	.289
0.76	.030	6.86	.270
0.25	.010	6.10	.240
0.13	.005	5.99	.236
0.08	.003	5.72	.225
0.05	.002	5.33	.210
0.00381	.000150	5.08	.200
0.00127	.000050	3.86	.152
0.00076	.000030	3.68	.145

CONVERSION TABLE

MATERIAL	FINISH	MATERIAL	COLOR	PART NO.
BRASS	8	NYLON, UL94V-0	WHITE	1-770966-1
BRASS	7	NYLON, UL94V-0	WHITE	1-770966-0
BRASS	6	NYLON, UL94V-0	WHITE	770966-2
BRASS	5	NYLON, UL94V-0	WHITE	770966-1

THIS DRAWING IS A CONTROLLED DOCUMENT.

DIMENSIONS: mm	TOLERANCES UNLESS OTHERWISE SPECIFIED:	DIN S. CARPENTER 24JUL2003	APVD C. JONES 24JUL2003	NAME
0 PLC ± -	1 PLC ± -	2 PLC ± 0.13	3 PLC ± -	4 PLC ± -
ANGLES ± -				
MATERIAL SEE TABLE	FINISH SEE TABLE	WEIGHT -	SIZE A1	CAGE CODE 00779
CUSTOMER DRAWING		SCALE 5:1	SHEET 1 OF 1	REV G

STE TE Connectivity  
HEADER ASSEMBLY, RIGHT ANGLE, WITH SHORT PEG, 2 CIRCUIT, MINI UNIVERSAL MATE-N-LOK(TM)